

## auto electrical parts

### Technical Information Sheet

#### Part No. 0-538-53

A very powerful 35 watt 12/24 volt HID Xenon work lamp with internal ballast. Black nylon plastic body and glass lens with stainless steel bracket and 250 mm flying lead. Supplied with Xenon bulb. Protected to IP65. l 120 x w 135 x h 160 mm.



#### Technical Drawing (not to scale)

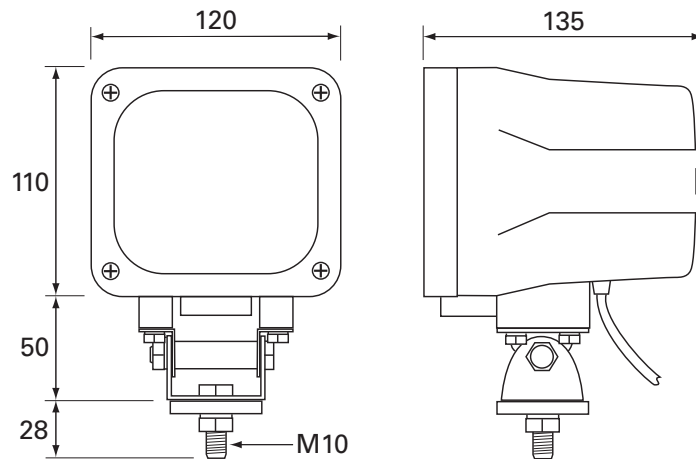

#### Specification

Type	HID Xenon work lamp
Voltage	12/24 volt dc
Current	3.5 amps at 12 volts dc
Xenon bulb	H3 (6000K)
Light intensity	3000 lumen
Housing	High impact Nylon
Bracket	Stainless steel
Lens	Glass
Degree of protection	IP65
Operating temperature	-45°C to + 85°C
Weight	1.02Kg
Dimensions	l 120 x w 135 x h 160 mm

The information contained in this document is correct to the best of our knowledge at the time of printing. However, specifications may change at any time without notice.